

General :

The MPCC has been designed for easy implementation of AC control functions that use a Passive Infra-Red (PIR) motion detector. Due to its high sensitivity and reliability, it is also widely used in security product.

- Minimum external component
- High sensitivity
- High RFI immunity
- Daylight adjustment
- Off delay timer

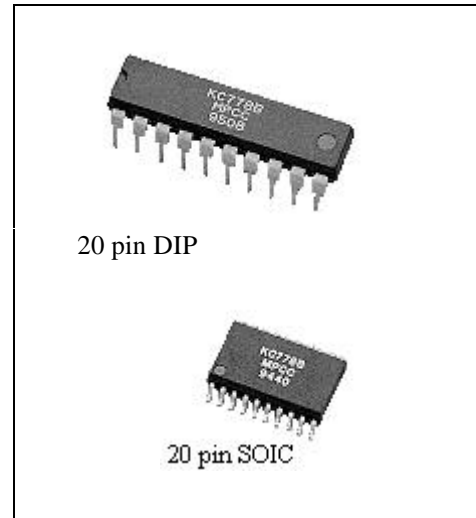

Features:

- A) Circuit design maximizes performance while minimizing external component count and board layout space.
- B) Low cost solution for PIR motion control switching applications.
- C) High sensitivity PIR input with special noise cancellation circuitry.
- D) Choice of two PIR gain settings: 62 db and 68 db.
- E) Adjustable PIR sensitivity.
- F) Internal switched capacitor bandpass filter reduces external component count and improves reliability by minimizing sensitivity to external component values.
- G) RFI noise immunity exceeds 30 V/m from 1 MHz to 1000 MHz.
- H) High immunity to line frequency noise.
- I) Daylight detector circuitry is designed to use either silicon photo diode or CdS detector.
- J) Adjustable daylight detector sensitivity.
- K) Adjustable OFF timer accuracy is determined by external components.
- L) Output can directly drive TRIACs, opto-couplers and small relays (no buffering required).
- M) Four main operating modes can be used in any combination:
 - 1)Auto-ON: Load turns on when motion is detected (adjustable sensitivity). Adjustable daylight detector disables Auto-ON during daytime. Auto-ON mode can be disabled. Daylight detector can be disabled.
 - 2)Auto-OFF: Adjustable OFF timer activates whenever motion stops. Load turns off if there is no motion during the time delay. If Auto-ON mode is disabled, the load will turn on if there is motion within 6 seconds after turn-off. (If the load goes off because you stopped moving (reading a book for example), you have 6 seconds to wave your arm to turn the load back on.) Auto-OFF mode can be disabled.
 - 3)Manual-ON: Load turns on manually, with a momentary contact switch.
 - 4)Manual-OFF: Load turns off manually, with a momentary contact switch. Load will remain off for 25 seconds, even if there is motion during this time (to give you time to leave the room).
- N) If the ON/AUTO/OFF input is held either high or low, the load will be held ON or OFF respectively, overriding all other modes, until the input returns to the AUTO position.
- O) If the Toggle input is held low, the load will change from on to off or from off to on, and will be held in that state, overriding all other modes, until the input returns high.
- P) When power is restored after an outage, the load will be OFF and motion will be ignored for 25 seconds.
- Q) Operating chip voltage is 4 - 15V.
- R) Operating chip current is typically 300 μ A.
- S) Chip is ESD protected to more than 1000 V (human body model).
- T) Operates with 50-60 Hz AC line frequency.

Pin Assignment :

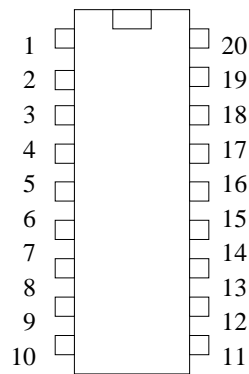

20 pin DIP or SOIC

Pin	Name	Description
1	Vcc	Supply Voltage (5 V)
2	Sensitivity Adjust	PIR Motion Sensitivity Input
3	Offset Filter	PIR Motion Offset Filter
4	Anti-Alias	PIR Anti-Alias Filter
5	DC CAP	PIR Gain Stabilization Filter
6	VReg	Voltage Regulator Output
7	Pyro (D)	Pyro Drain Reference
8	Pyro (S)	Pyro Source Input Signal
9	Gnd (A)	Analog Circuitry Ground
10	Gnd (D)	Digital Circuitry Ground
11	Daylight Adjust	Daylight Adjustment and CdS Input
12	Daylight Sense	Silicon Photo Diode Input
13	Gain Select	PIR Gain Select Tri-State Input
14	ON/AUTO/OFF	Mode Select Tri-State Input
15	Toggle	Mode Select Toggle Input
16	OUT	Lights ON/OFF Output
17	LED	PIR Motion Indicator Output
18	C	OFF Timer Oscillator Input
19	R	OFF Timer Oscillator Output
20	FRef	Frequency Reference Oscillator

Pin Descriptions

- 1. Vcc :** This is the regulated supply voltage to the chip (nominally 5 V).
- 2. Sensitivity Adjust:** This pin is used to adjust the sensitivity threshold of the motion comparators. When the voltage on this pin equals the pyro drain reference voltage on pin 7 the PIR sensitivity will be minimum (± 500 mV). When the voltage on this pin is Gnd the PIR sensitivity will be maximum (± 125 mV). Intermediate voltages will provide intermediate sensitivities.
- 3. Offset Filter:** This pin connects to an external capacitor of 10 μ F and holds the average value of the switched capacitor bandpass filter output. Motion is detected when the difference between this average and the actual filter output is greater than the sensitivity setting. The output of the switched capacitor bandpass filter can be seen directly on this pin if the external capacitor is disconnected, however, motion will not be detected under these conditions.
- 4. Anti-Alias:** This pin connects to an external capacitor of 0.1 μ F providing low pass filtering of the PIR input signal, blocking input signals at and above the switching frequency of the switched capacitor bandpass filter.

- 5. DC CAP:** This pin connects to an external capacitor of 10 μF and holds the average pyro source voltage. The difference between this average and the actual pyro source voltage is amplified and coupled to the switched capacitor bandpass filter. The 10 μF capacitor must be a low leakage capacitor, such as a Tantalum capacitor.
- 6. VReg:** This pin outputs a voltage that can be used directly drive an external NPN/PNP voltage regulator, or the gate of an external depletion mode JFET voltage regulator pass element. This pin need not be connected if an external voltage regulator, such as a three pin regulator, is used to generate V_{cc} for the chip.
- 7. Pyro (D):** The pyro drain reference voltage is output on this pin. This voltage is power supply independent and is connected internally to special noise cancellation circuitry to improve the performance and reliability of the PIR interface. Externally, this pin is connected to the pyro drain and to a 0.1 μF capacitor. This voltage can also be divided down by an external pot to supply the Sensitivity Adjust voltage to pin 2.
- 8. Pyro (S):** This is the pyro source input pin that receives the PIR input signal. It is connected externally to the pyro source, a 200 pF capacitor and a 47 K Ω resistor to Gnd. This is a **sensitive** node and the length of the external interconnect to this pin should be made as short as possible. There should be a ground plane on the PC board under the PIR sensor.
- 9. Gnd (A):** This pin is the electrical ground for the internal analog circuitry of the chip.
- 10. Gnd (D) :** This pin is the electrical ground for the internal digital circuitry of the chip.
- 11. Daylight Adjust:** This pin is the output of the Daylight Sense amplifier and the input to the daylight comparator. When using a silicon photo diode daylight sensor, this pin is connected to Daylight Sense (pin 12) by a resistor or pot. The amount of resistance determines the gain of the Daylight Sense amplifier and hence the sensitivity of the daylight detector. When using a CdS daylight sensor, a pot is connected between this pin and V_{cc} , while the CdS sensor is connected across one side of the pot (two fixed resistors can be used instead of the pot). Daylight Sense (pin 12) must be connected to V_{cc} when using a CdS sensor. To disable the daylight detector, Daylight Adjust (pin 11) must be unconnected and Daylight Sense (pin 12) must be connected to V_{cc} . To disable Auto-ON mode, Daylight Adjust (pin 11) and Daylight Sense (pin 12) must both be connected to V_{cc} (the daylight detector is not used when Auto-ON mode is disabled).
- 12. Daylight Sense:** This pin is the input to the Daylight Sense amplifier. When using a silicon photo diode daylight sensor, this pin is connected to the cathode of the silicon photo diode and to a feedback resistor (or pot) from Daylight Adjust (pin 11). In all other cases, this pin is connected to V_{cc} .
- 13. Gain Select:** The Gain Select pin is a tri-state input used to select the gain of the PIR circuitry. When this pin is connected to Gnd, the PIR gain is set to 62 db. When this pin is unconnected or connected to V_{cc} , the PIR gain is set to 68 db. Normally this pin is unconnected except when less gain is required by a particular PIR sensor.
- 14. ON/AUTO/OFF:** This pin is a tri-state input used to determine the operation of the chip. Normally this pin is unconnected, allowing the chip to operate in its configured operating mode. If this pin is connected to Gnd, the load will turn off unconditionally and will remain off as long as this pin is connected to Gnd. If this pin is connected to V_{cc} , the load will turn on unconditionally and will remain on as long as this pin is connected to V_{cc} .
- 15. Toggle:** This pin is a toggle input used to determine the operation of the chip. Normally this pin is unconnected, allowing the chip to operate in its configured operating mode. If this pin is connected to Gnd, the load will change from on to off or from off to on and will remain in the new state unconditionally as long as this pin is connected to Gnd. If the ON/AUTO/OFF (pin 14) and Toggle (pin 15) switches are pressed such that one is trying to turn the load on unconditionally and the other is trying to turn the load off unconditionally, the load will be turned off (off overrides on).
- 16. OUT :** The output from this pin is used to turn the external load on or off through a TRIAC, relay or opto-coupler. The impedance of this pin is less than 35 Ω , enabling it to directly drive a small (100 Ω DC coil resistance) pulse relay through a 150 μF series capacitor. For proper operation, the load should come on when this pin goes high, the load should go off when this pin goes low.

- 17. LED:** The output from the motion comparator drives this pin through an internal 500 Ω current limiting resistor, enabling it to directly drive an LED motion indicator. Whenever motion is detected this pin will go high and the LED will light. When there is no motion this pin will be low.
- 18. C:** This pin is the input to the OFF timer oscillator. It is connected externally to a pot (or resistor) from R (pin 19) and to a capacitor. The OFF timer delay, in seconds, will be $5678 \times (40,000 + \text{pot resistance in Ohms}) \times (\text{capacitance in Farads})$. To disable Auto-OFF mode, this pin can be connected to Gnd or Vcc. For minimum time delay, C(pin 18) and R(pin 19) can be shorted together with no external resistor or capacitor. In this configuration, the output at OUT(pin 16) should be the same as the output at LED(pin 17).
- 19. R :** The output of the OFF timer oscillator drives this pin through an internal 40 K Ω series resistor. This pin is connected externally to C (pin 18) through a pot (or resistor). This pin can be connected directly to C (pin 18) for the minimum OFF timer delay (maximum oscillator frequency).
- 20. FRef :** This is the 160 Hz reference oscillator input. It is connected externally through a 330K Ω resistor to Vcc and a 0.022 μ F capacitor to Gnd. Other values of resistance and capacitance can be chosen, provided this input oscillates at 160Hz. This frequency is used to drive the internal switched capacitor bandpass filter and the timing delays.

Electrical Specifications

Below are the specifications at room temperature (25 °C).

Parameter	Min.	Typ.	Max.	Unit
Vcc	4	5	15	V
Icc		300		μ A
Input Voltage on any Pins	Gnd - 0.5		Vcc + 0.5	V
PIR Power Supply Rejection Ratio	74			dB
PIR Input Gain	62		68	dB
Overall gain variation			5	%
Overall threshold variation			7	%
Daylight Adjust (pin 11) Pull-down Current		5		μ A
Gain Select (pin 13) Pull-up Current		5		μ A
ON/AUTO/OFF (pin 14) Pull-up Current		10		μ A
ON/AUTO/OFF (pin 14) Pull-Down Current		10		μ A
Toggle (pin 15) Pull-up Current		5		μ A
Pyro (D) (pin 7) Reference Voltage	2.3	2.5	2.7	V
OUT (pin 16) Output Impedance			35	Ω
LED (pin 17) Output Impedance	375	500	625	Ω
R (pin 19) Output Impedance	30	40	50	K Ω
Operating Temperature	-25		+100	$^{\circ}$ C
Storage Temperature	-55		+125	$^{\circ}$ C

Application Notes:

- Normally, Gain Select (pin 13) is unconnected, providing a PIR gain of 68 db. For reduced sensitivity, Gain Select is connected to Gnd, providing a gain of 62 db.
- Auto-ON mode can be disabled by connecting both Daylight Sense (pin 12) and Daylight Adjust (pin 11) to Vcc.
- Auto-OFF mode can be disabled by connecting C (pin 18) to Gnd or Vcc.
- Daylight detector can be disabled by connecting Daylight Sense (pin 12) to Vcc.
- With a 5 M Ω Daylight adjust pot, the daylight sensitivity can be adjusted from complete darkness (always on) to complete daylight (always off). Additional fixed resistors and possibly a smaller pot can be used to restrict the range for specific applications.
- The OFF timer range can be set by selecting a pot and capacitor and possibly additional fixed resistors that will produce the minimum and maximum time delays at the extremes of the pot.

7. OFF timer delay = $5678 \times (R+40,000) \times C$ seconds, R is in Ohms, C is in Farads.
8. The Sensitivity Adjust pot is used to select a voltage between the pyro drain reference voltage (minimum sensitivity) and Gnd (maximum sensitivity). The value of the pot is not critical and any value between 100 K Ω and 5 M Ω can be used.
9. The output of the switched capacitor bandpass filter can be seen on pin 3 (Offset Filter) when the external capacitor(10 μ F) is disconnected. The filter response can be measured in this way. (Disconnecting the external capacitor prevents motion from being detected.)
10. Pin 8 (Pyro (S)) is a **sensitive** node and the external interconnect to this pin should be made as short as possible. This node should also be closely surrounded by a ground plane.

Block Diagram

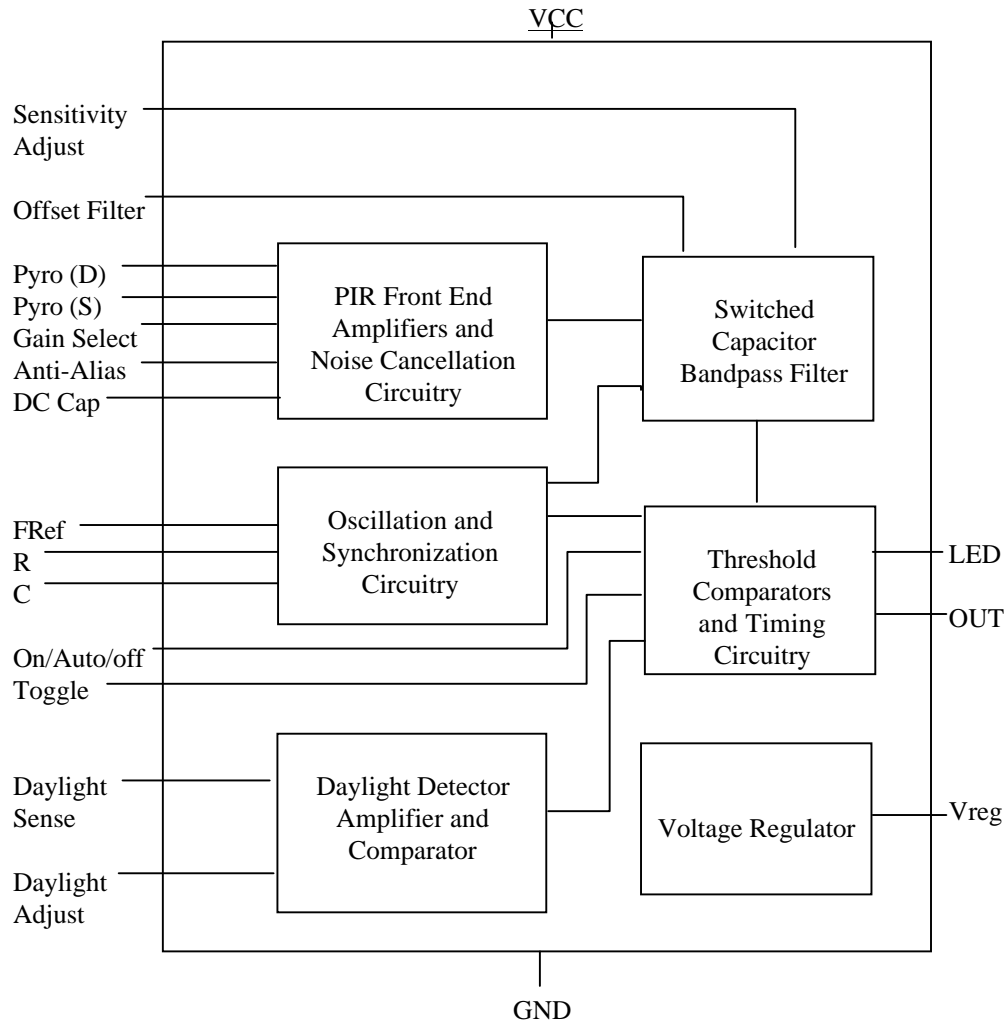

Application Circuit

1. Typical Hook-up

Below is a typical hook up for connecting KC778B to a PIR sensor, a TRIAC light switch and a silicon photodiode daylight detector. VReg is used for voltage regulation. 2 slide switches are used. One for select ON/AUTO/OFF and the other one used for enable, disable the daylight sensor and disable auto-on function. A simple AC regulation circuit is used in this system such that only a small gate current TRIAC can be used.

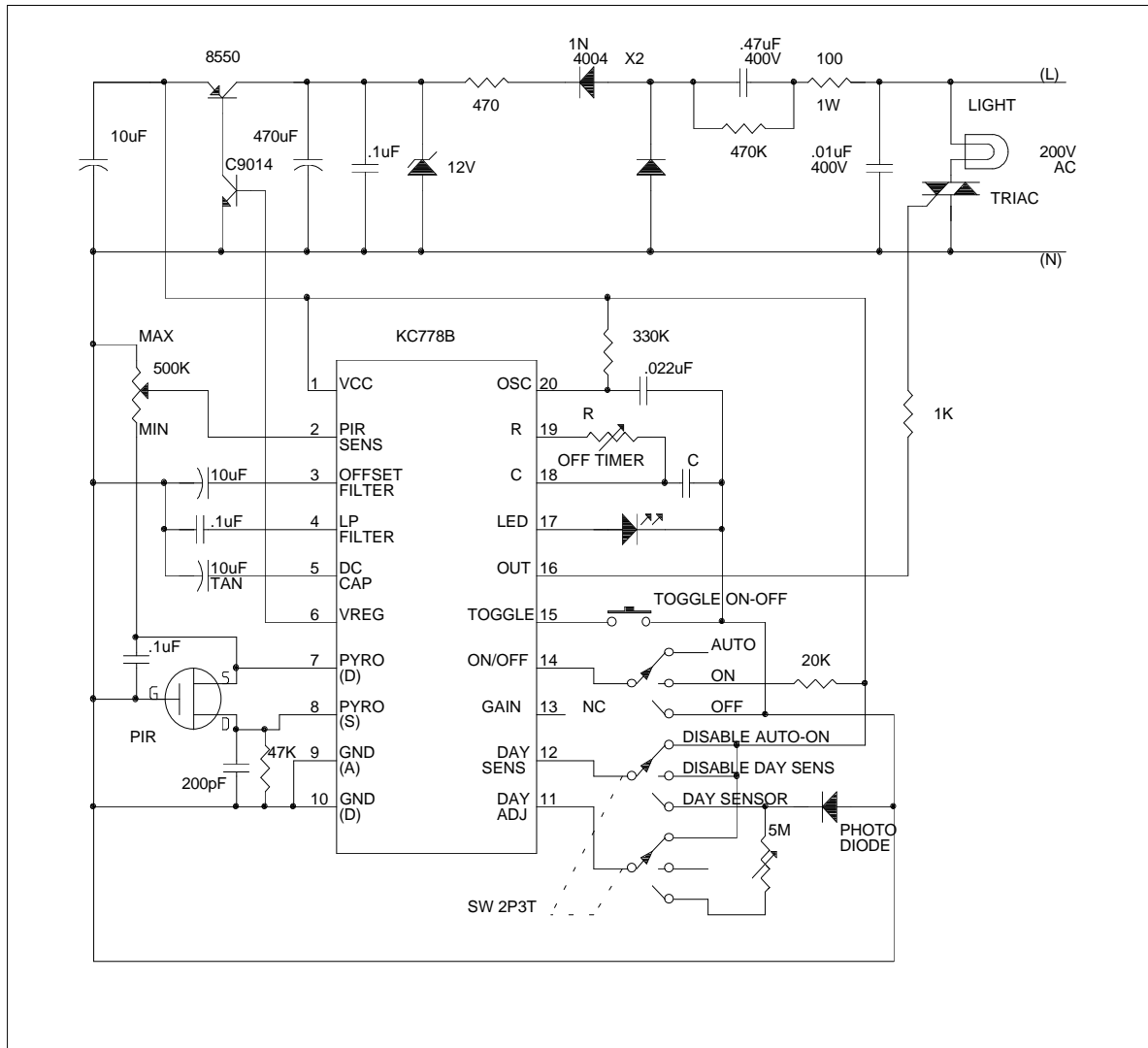

Note : Off Time Delay = $5678 \times (R+40,000) \times C$ Second
 R in Ohm, C in Farad

2. Hook-up with with relay

The following is similar to the typical hook-up. Due to the higher current require by relay, the bridge regulation method is used in AC circuit. This application is suitable to a high current loading such as heater, flood light, motor and etc.

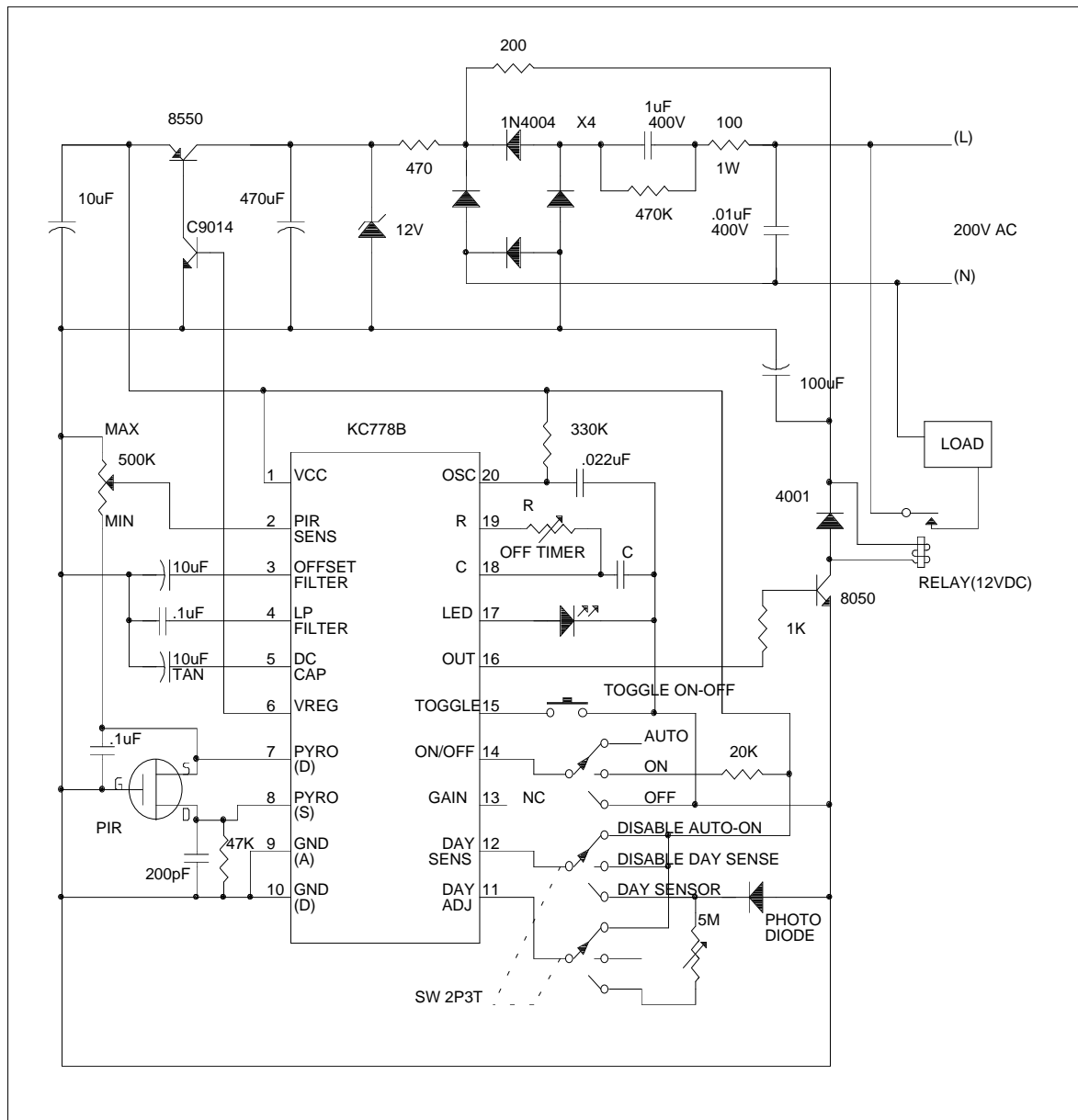

Note : Off Time Delay = $5678 \times (R+40,000) \times C$ Second
R in Ohm, C in Farad

3. Hook-up with minimum regulator

Below is an example of 110V application. Only one stages of regulator is used in the system by use of zener diode

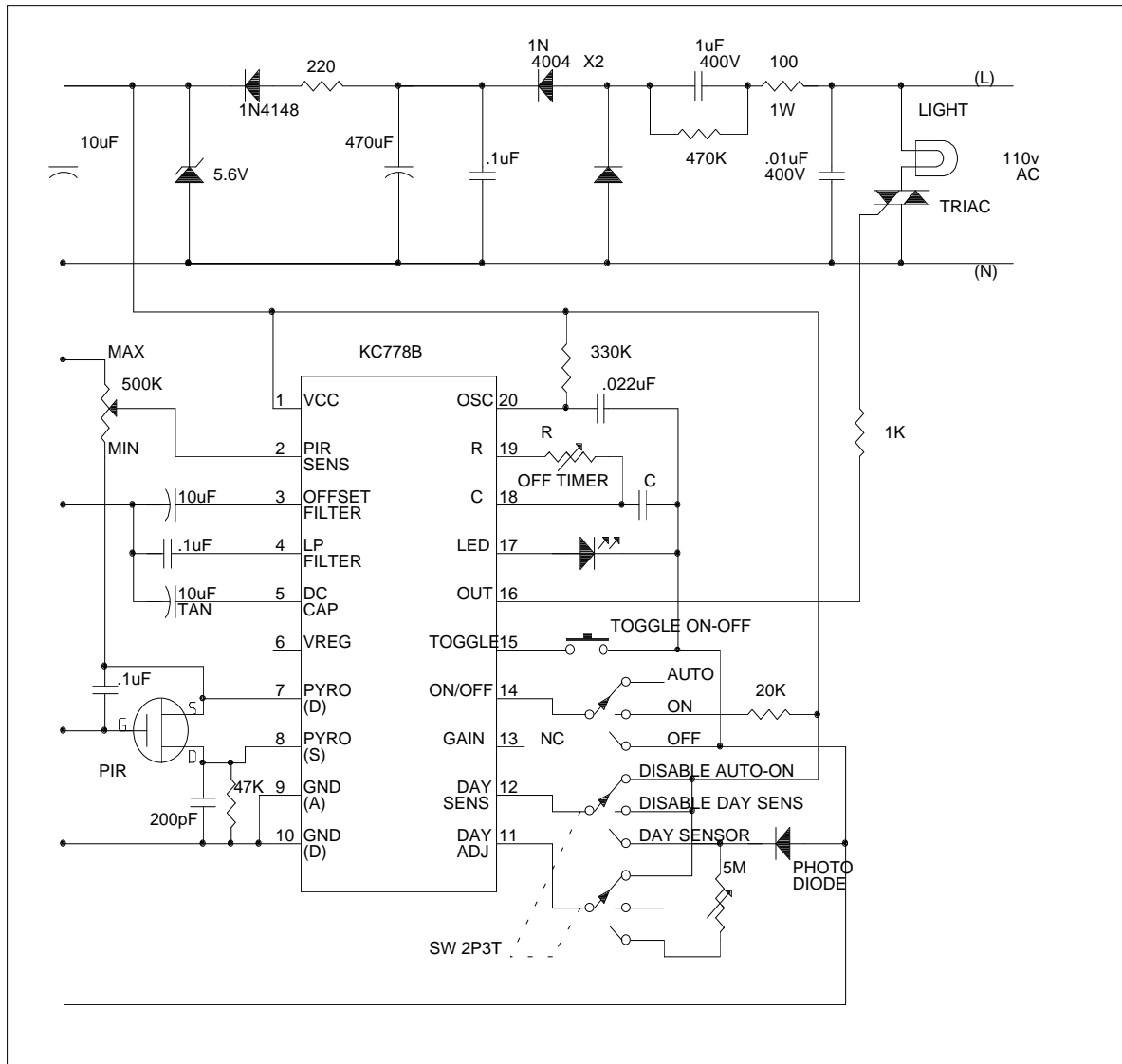

Note : Off Time Delay = $5678 \times (R+40,000) \times C$ Second
 R in Ohm, C in Farad

4. Hook-up with 12VDC system

Below is an example of Auto camp light which uses an auto battery (12VDC). Internal voltage regulator is used, it needs 12V to start up but can work down to 7V.

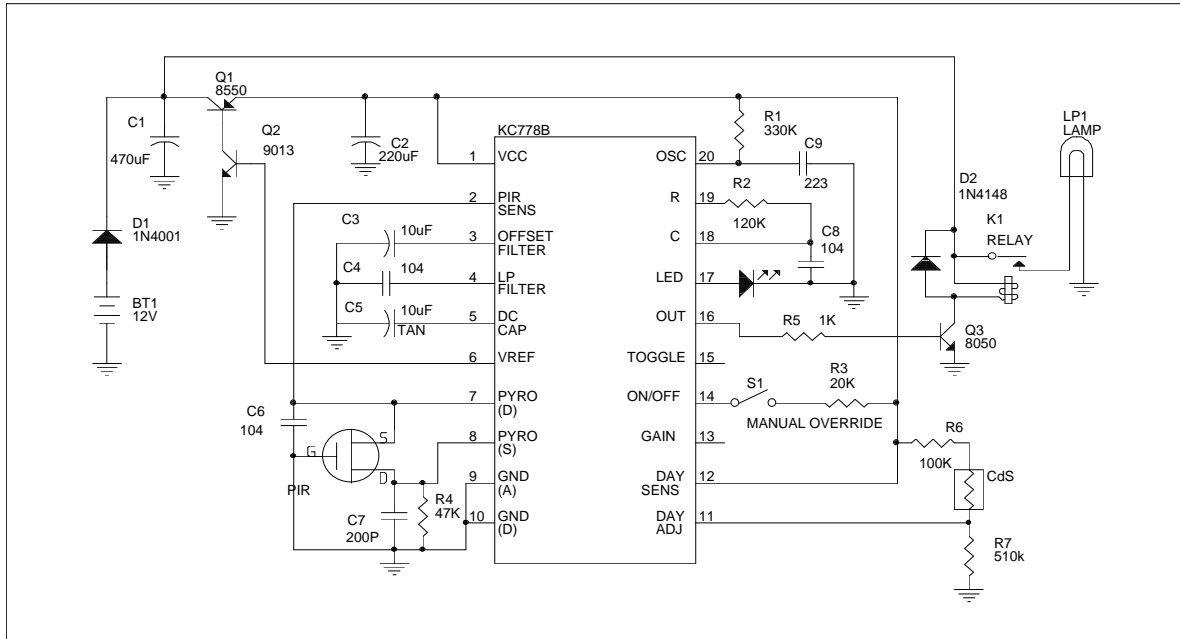

5. Hook-up with Door Chime and Alarm circuit

A 2P3T slide switch is used in the system. When it is positioned at Chime, the LED output of KC778B will trigger the door bell COB at anytime. If the switch is positioned at OFF, power will be cut off. When switch to Alarm position, after 25sec delay, the KC778B start working. It outputs a high signal when motion is detected. This signal will charge up the cap such that the siren COB will be triggered after the charge up delay time. It forms a very simple alarm product.

