

产 品 规 格 书

Product Specification

光敏三极管

(PT850-1206)

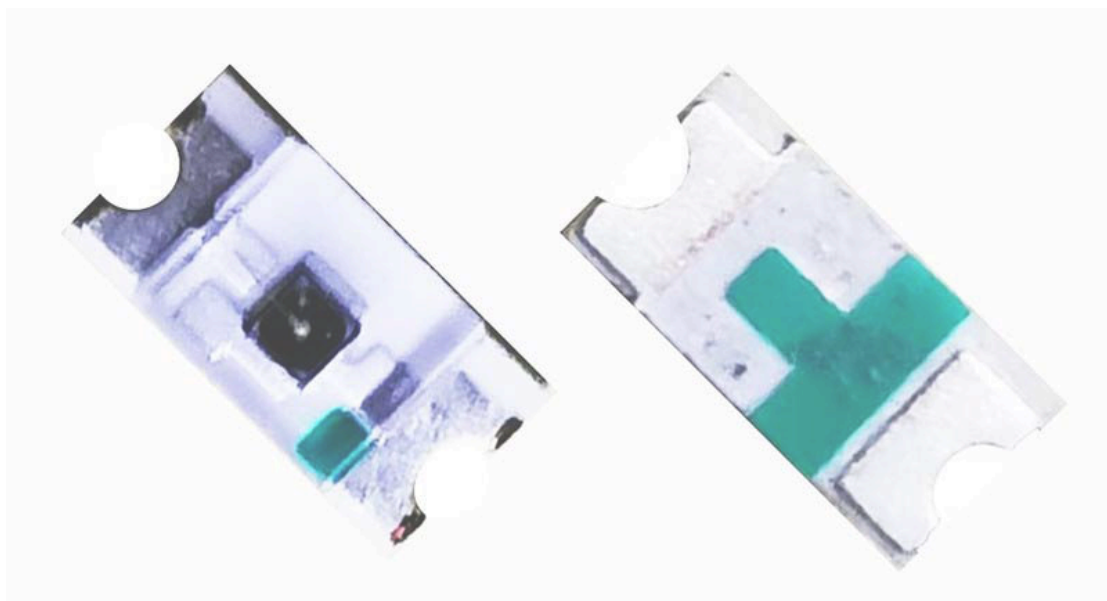

PT850-1206 (24)

产品外型尺寸 product Dimensions:

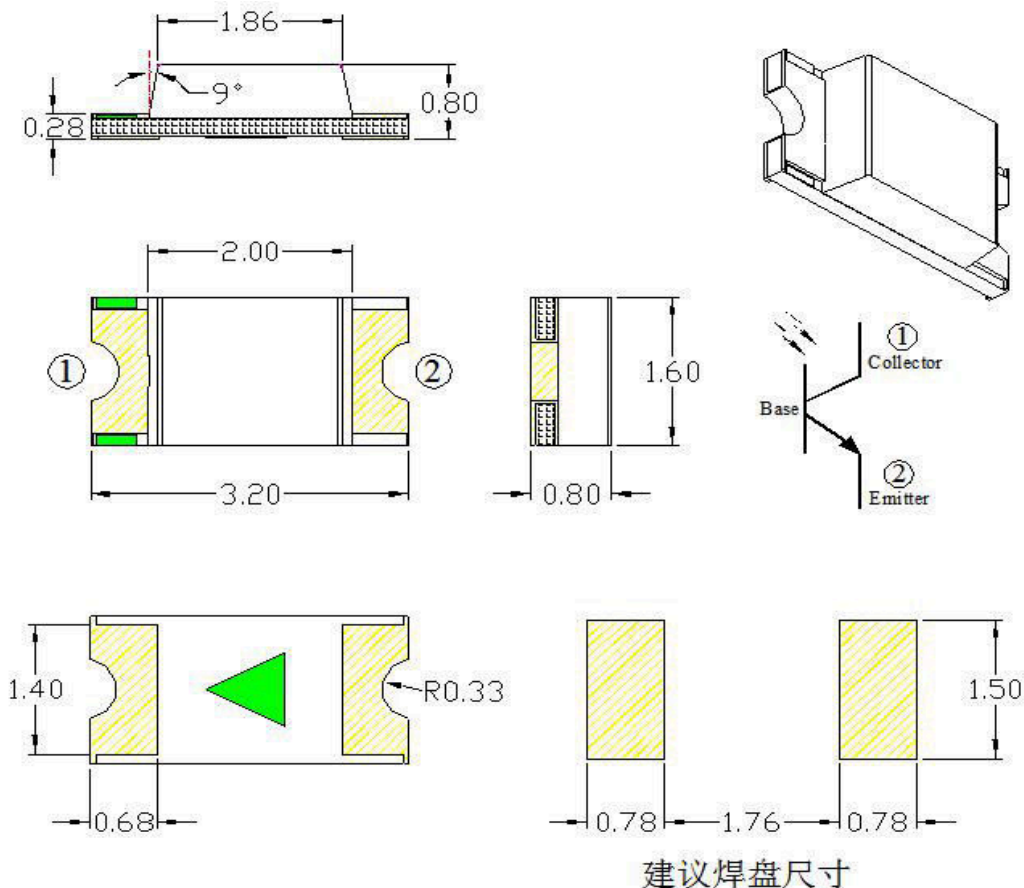

注 Notes:

1. 所有尺寸都以毫米为单位 (All dimensions are in millimeters).
2. 公差为±0.20 毫米除非另有说明 (Tolerance is ±0.20mm unless otherwise noted).

特征 Features

响应时间快 (Fast response times)。
 高光敏性 (High photo sensitivity)。
 小结电容 (Small junction capacitance)。
 替代传统 CDS 光敏电阻, 不含镉、铅等有害物质, 符合欧盟 ROHS 标准 (Instead of the traditional CDS photosensitive resistance, contain cadmium, lead and hazardous substances, ROHS compliant)。用于光控类产品, 控制昼夜切换 (For optical control products, control day and night switching)。

绝对最大额定值 Absolute Maximum Ratings (Ta = 25°C)

参数 Parameter	符号 Symbol	最大额定值 Rating	单位 Units
集电极发射极电压 Collector-Emitter Voltage	VCE0	30	V
发射极集电极电压 Emitter - Collector Voltage	VECO	5	V
集电极电流 Collector Current	IC	20	mA
工作环境温度 Operating Temperature	Topr	-25~+80	°C
储存环境温度 Storage Temperature	Tstg	-40~+85	°C
焊接温度 Lead Soldering Temperature	Tsol	260	°C
功耗 Power Dissipation	PC	75	mW

■ 光电特性 Electro-Optical characteristics (Ta=25°C)

参数 Parameter	符号 Symbol	条件 Condition	最小值 Min.	中间值 Typ.	最大值 Max.	单位 Units
集电极发射极击穿电压 Collector-Emitter Breakdown Voltage	BVCE0	Ic=100 μ A Ee=0mW/cm ²	30	---	70	V
发射极集电极击穿电压 Emitter-Collector Breakdown Voltage	VECO	IE=100 μ A Ee=0mW/cm ²	5	---	---	V
集电极发射极饱和电压 Collector-Emitter Saturation Voltage	VCE (sta)	Ic=2mA Ee=1mW/cm ²	---	---	0.4	V
启动延时 Rise time	Tr	VCE=5V Ic=1mA	---	15	---	μ S
关闭延时 Fall Time	Tf	RL=1000 Ω	---	15	---	
暗电流 Collector Dark Current	ICE0	Ev=0mW/cm ² VCE=20V	---	---	100	nA
亮电流 On StatCollector Current	IC (on)	Ev=10lux 590nmVCE=5v	3	4.5	6	uA
接收峰值光谱 Wavelength of Peak Sensitivity	λ p	---	400	850	1100	nm

■ 感光特性 Photosensitivity

图一：光谱敏感度曲线

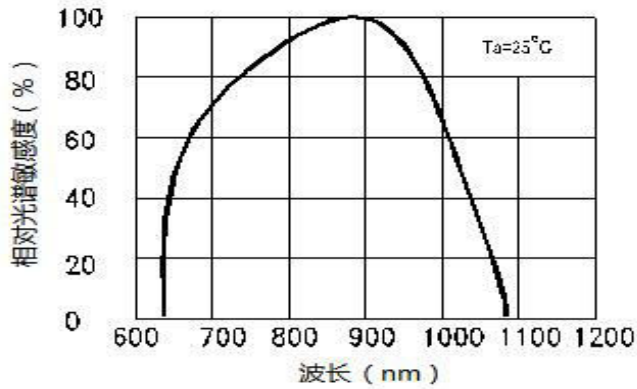

图二：集电极暗电流VS环境温度曲线

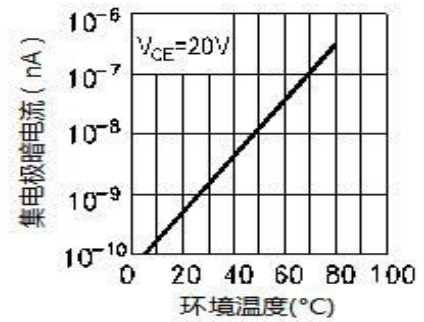

图三：耗散功率VS环境温度曲线

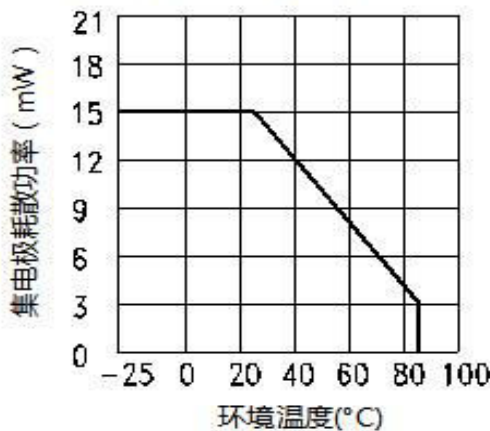

图四：相对集电极电流强度VS环境温度曲线

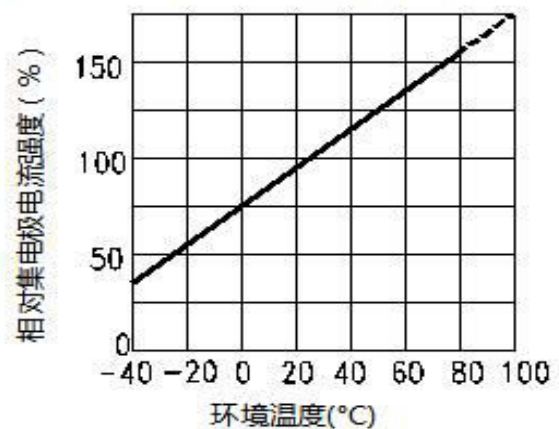

图五：集电极电流VS辐射照度

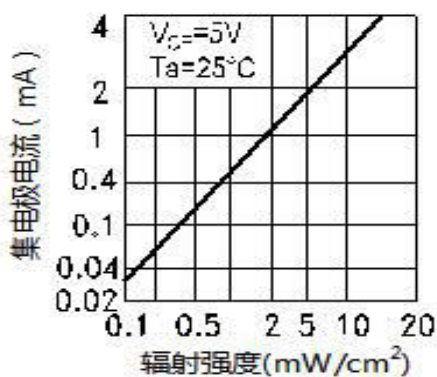

图六：光电流VS V_{CE0}曲线

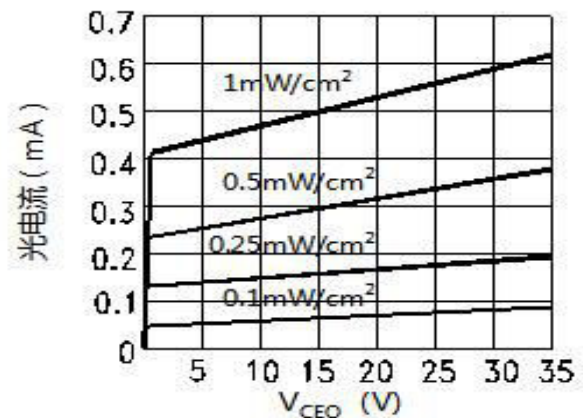

■ 一般应用电路

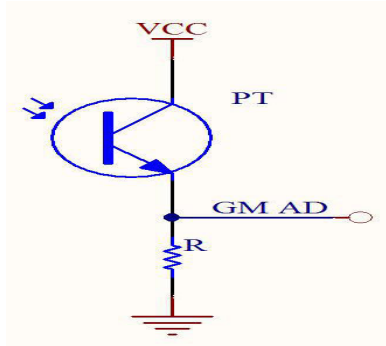

■ 推荐焊接条件 Recommended Soldering Conditions

焊接模式 Mode		固定形式 Fixed form
手工焊接 Manually Soldering	烙铁温度 Soldering Iron Temperature	最高温度 300℃ (功率最大 30 瓦) 300℃ Max (30w Max)
	焊接时间 Soldering Time	时间不超过 3 秒 3 sec Max
	焊接位置 Soldering Position	大于 3mm (从焊点到胶体) 3mm Min. (Form soldering joint to colloid)
波峰焊接 Wave Soldering	预热 Preheat	最高温度 100℃ 不超过 60 秒 100℃ Max. 60 sec. Max
	温度 Temperature	最高 260℃ 260℃ Max.
	焊接时间 Soldering Time	不超过 5 秒 5 sec Max
锡炉焊接 Solder pot Soldering	预热 Preheat	最高温度 100℃ 不超过 60 秒 100℃ Max. 60 sec. Max
	浸焊温度 Preheat Temperature	最高 260℃ 260℃ Max.
	浸焊时间 Soldering Time	不超过 5 秒 5 sec Max
	焊接位置 Soldering Position	大于 2mm (从焊点到胶体) 2mm Min. (From soldering joint to colloid)

备注: 请严格按照产品承认书的焊接条件规范作业。(Note: please operate in strict accordance with the welding condition specification in the product acceptance letter.)

■ 注意事项 Precautions

储存 store

※该产品出厂后贮存的条件应为 0~+30℃、相对湿度小于 70%，密封贮存期限为 3 个月。若贮存超过 3 个月，则应放在带有氮气和干燥剂的密闭容器内，贮存时间可达一年（The product after the factory storage conditions should be 0 ~ +30 °C, relative humidity less than 70%, sealed storage period of 3 months. If stored for more than 3 months, it should be placed in a sealed container with nitrogen and desiccant for up to one year）；

※拆袋使用，应尽可能短时间内用完。若用不完，应满足贮存条件应为 0~+30℃、相对湿度不小于 60%，并在 2 天内安装完。产品支架是铁合金表面上镀银，银表面会受到腐蚀性气体等环境的影响，这将会导致产品焊接困难（Bundled use, should be used as soon as possible within a short time. If you can not finish, should meet the storage conditions should be 0 ~ +30 °C, relative humidity of not less than 60%, and installed in 2 days. Product stent is silver on the surface

of silver, silver surface will be corrosive gases and other environmental impact, which will lead to product welding difficulties）。

安装 installation

※产品安装在 PCB 上，不能对引脚有压力施加（PCB board hole must be consistent with the product pin spacing, otherwise it will easily damage the product）。

焊接 welding

※胶体不可浸入锡槽内（Colloids can not be immersed in tin tanks）；

※加热过程中不能对引脚有施加压力（The pressure can not be applied to the pins during heating）；

※推荐焊接条件：波峰焊：120℃ <60s、260℃ <5s；手工焊：260℃ <5s、340℃ <3s（Recommended welding conditions: wave soldering: 120 °C <60s, 260 °C <5s; manual welding: 260 °C <5s, 340 °C <3s）。

清洗 Cleaning

※清洗产品时推荐使用酒精作为清洗剂。如使用其他清洗剂，需先确认清洗剂是否会腐蚀环氧体。氟利昂不能作为清洗剂；（Alcohol is recommended for cleaning products. If other cleaning agents are used, check if they will corrode the epoxy. Freon cannot be used as cleaning agent.）

※不可用水清洗，以免腐蚀引线，建议使用酒精；（Do not clean with water to avoid corroding the lead wire. Alcohol is recommended））

※本型号为静电敏感器件，要求佩带防静电腕带，所有的装置、设备、机器、桌子、地面都必须防静电接地。（This model is an electrostatic sensitive device. It is required to wear an anti-static wristband when using. All devices, equipment, machines, tables and floors must be anti-static grounded.）